



FAL - Fabryka Armatur Sp. z O.O.

ul. Koniecpolska 38, 04-267 Warszawa

Zakład produkcyjny: ul. Jedności Narodowej 9, 74-240 Lipiany

tel. centr.: (0048) (091) 564 11 59; tel. / fax: (0048) (091) 564 13 79 e-mail: fal@fal.pl, http://www.fal.pl

FIG 11/II

PN 2,5; PN 4; PN 6; PN 10;
PN16

 **Zasuwa kołnierzowa klinowa
płaska z uszczelnieniem
oring / DIN 3352**

ZASTOSOWANIE

Temperatura	Ciśnienie MPa
393K (120°C)	0,25; 0,4; 0,6; 1,0; 1,6

- media nieagresywne
- owiercenie DIN 2501
- długość budowy DIN 3202F₄

 **Flanged flat wedge gate valve
with O-ring packing / DIN 3352**

APPLICATION

Temperature	Pressure MPa
393K (120°C)	0,25; 0,4; 0,6; 1,0; 1,6

- for non-aggressive media
- flange drilled according to DIN 2501
- F to F dimension DIN 3202F₄



ISO 9001:2000

 **Keilflachschieber mit
O-Ringpackung /DIN 3352**

VERWENDUNGSBEREICH

Temperatur	Druck MPa
393K (120°C)	0,25; 0,4; 0,6; 1,0; 1,6

- für nichtaggressive Medien
- flanschbohrung nach DIN 2501
- baulänge nach DIN 3202F₄

 **Vanne méplate avec garniture
O-ring /DIN 3352**

CONDITION DE SERVICE

Température	Pression MPa
393K (120°C)	0,25; 0,4; 0,6; 1,0; 1,6

- pour les agents non-agressifs
- brides percées conformément à DIN 2501
- dimension entre brides DIN 3202F₄

:: Materialy :: :: Materials :: :: Werkstoffe :: :: Matières ::

	Wariant / Execution / Variante / Execution	1	2
1	Kadłub / Body / Gehäuse / Corps	EN-GJL-250 (EN 1561:1997)	
2	Pokrywa / Bonnet / Deckel / Couvercle		
3	Klin / Wedge / Keil / Opucule		
4	Kółko / Handwheel / Handrad / Volant á main		
5	Pierścień klina i kadłuba / Body and wedge packing rings / Gehäuse und Kaildichtungsringe / Bogues d'étanchéité du corps et de l'opucule	CuZn39Pb2 (EN 1652:1997)	X20Cr13 (EN 10088:1995)
6	Trzpień / Steam / Spindel / Tige	X20Cr13 (EN 10088:1995)	
7	Nakrętka trzpienia / Steam nut / Spindelmutter / Écrou de la tige	CuZn39Pb2 (EN 1652:1997)	

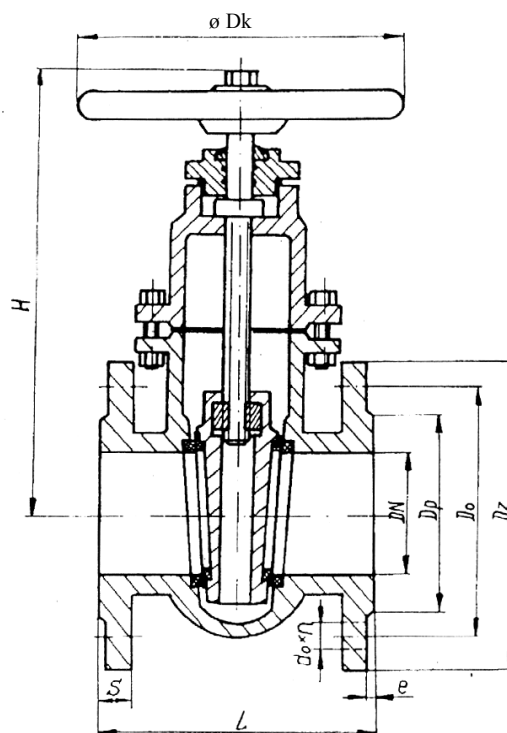

Kołnierze owiercane wg DIN 2501 na PN 0,6 MPa; 1,0 MPa; 1,6 MPa. Dla DN 250-600 owiercenie zgodnie z DIN 2501 PN 1,0 MPa

DN	Dz	Do	Dp	L	g	do	n	f	H	Dk	kg
40	150	110	88	140	18	18	4	3	222	160	11,36
50	165	125	102	150	20	18	4	3	227	160	13,36
65	185	145	122	170	20	18	4	3	263	180	19,03
80	200	160	138	180	22	18	8	3	290	180	24,03
100	220	180	158	190	22	18	8	3	335	200	29,00
125	250	210	188	200	24	18	8	3	363	240	37,32
150	285	240	212	210	24	22	8	3	407	240	44,30
200	340	295	268	230	26	22	8/12	3	485	240	77,60
PN 6 250	395	350	320	250	28	22	12	3	588	360	104,40
PN 6 300	445	400	370	270	28	22	12	4	675	360	145,40
PN 4 350	505	460	430	290	30	22	16	4	825	360	217,40
PN 4 400	565	515	482	310	32	26	16	4	890	360	264,40
PN 4 450	615	565	532	330	32	26	16	4		500	
PN 4 500	670	620	585	350	34	26	20	4	1130	500	477,00
PN 2,5 600	780	725	685	390	36	30	20	5	1300	500	726,00