



FAL - Fabryka Armatur Sp. z O.O.

ul. Koniecpolska 38, 04-267 Warszawa

Zakład produkcyjny: ul. Jedności Narodowej 9, 74-240 Lipiany

tel. centr.: (0048) (091) 564 11 59; tel. / fax: (0048) (091) 564 13 79 e-mail: fal@fal.pl, http://www.fal.pl

FIG 932

PN 2,5



Kosz ssący

ZASTOSOWANIE

Temperatura	Ciśnienie MPa
323K (50°C)	0,25

- media nieagresywne
- owiercenie DIN 2501



Foot valves

APPLICATION

Temperature	Pressure MPa
323K (50°C)	0,25

- for non-aggressive media
- flange drilled according to DIN 2501



ISO 9001:2000



Saugkorb

VERWENDUNGSBEREICH

Temperatur	Druck MPa
323K (50°C)	0,25

- für nichtaggressive Medien
- flanschbohrung nach DIN 2501



Crèpine

CONDITION DE SERVICE

Température	Pression MPa
323K (50°C)	0,25

- pour les agents non-agressifs
- brides percées conformément à DIN 2501

:: Materiały :: :: Materials :: :: Werkstoffe :: :: Matières ::

1	Górna część kosza / Uper part of suction rose / Oberteil des Fussventils / Partie haute de la crepine	EN-GJL-250 (EN 1561:1997)
2	Płyta dna / Bottom plate / Untere klappe / Partie basse	
3	Sito – cynkowane ogniowo / Screen side surface hot galvanizing / Siebmantelfläche / Surface latérale de tamis	RSt37-1 (EN 1025)
4	Łożysko kłapy / Hinge pin boss / Klappenlager / Palier de l'axe d'articulation du battant	Stal węglowa / Carbon steel / Kohlenstahl / Acier au carbone
5	Uszczelnienie kłapy	Guma / Rubber / Gummi / Caoutchouc

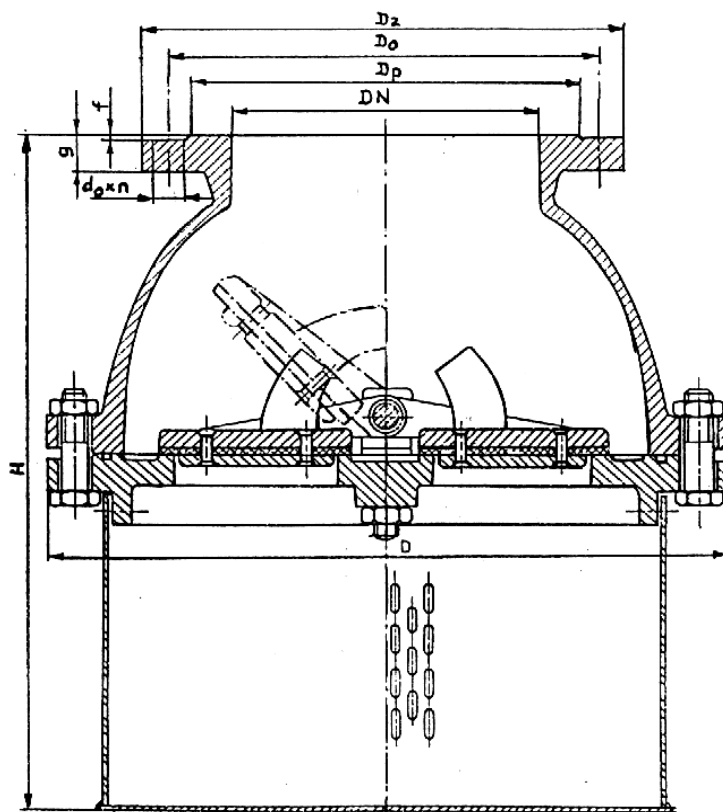

Średnica nominalna mm	Ciśnienie nominalne MPa	Ciśnienie próbne		Największe ciśnienie robocze przy temperaturze czynnika 323K (50°C) MPa
		kadłuba	zamknięcia	
350-400	0,25	0,5	0,25	0,25

DN mm	Pressure MPa	Test pressure		Acceptability working pressure with medium temperature 323K (50°C) MPa
		Body	Closure	
350-400	0,25	0,5	0,25	0,25

DN	H	D	Dz	Dp	Do	g	f	do	liczba otworów	kg
350	787	726	505	430	460	26	4	23	16	192,00
400	915	820	565	482	515	28	4	27	16	250,00