



# FAL - Fabryka Armatur Sp. z O.O.

ul. Koniecpolska 38, 04-267 Warszawa

Zakład produkcyjny: ul. Jedności Narodowej 9, 74-240 Lipiany

tel. centr.: (0048) (091) 564 11 59; tel. / fax: (0048) (091) 564 13 79 e-mail: fal@fal.pl, http://www.fal.pl

**FIG 935**

**PN 10**



**Kosz ssący**

## ZASTOSOWANIE

Temperatura	Ciśnienie MPa
373K (100°C)	1,0

- media nieagresywne
- owiercenie DIN 2501



**Foot valve**

## APPLICATION

Temperature	Pressure MPa
373K (100°C)	1,0

- for non-aggressive media
- flange drilled according to DIN 2501



**ISO 9001:2000**



**Saugkorb**

## VERWENDUNGSBEREICH

Temperatur	Druck MPa
373K (100°C)	1,0

- für nichtaggressive Medien
- flanschbohrung nach DIN 2501



**Crépine**

## CONDITION DE SERVICE

Température	Pression MPa
373K (100°C)	1,0

- pour les agents non-agressifs
- brides percées conformément à DIN 2501

.: Materialy .: .: Materials .: .: Werkstoffe .: .: Matières .:

1	Kadłub górny / Body / Oberteil / Corps	EN-GJL-250 (EN 1561:1997)
2	Kadłub dolny / Bottom / Gehäuse / Couverte	
3	Grzyb / Disk / Kegel / Clapet	
4	Sito – cynkowane / Screen side surface / Siebmantelfläche / Surface latérale de tamis	RS137-1 (EN 1025)

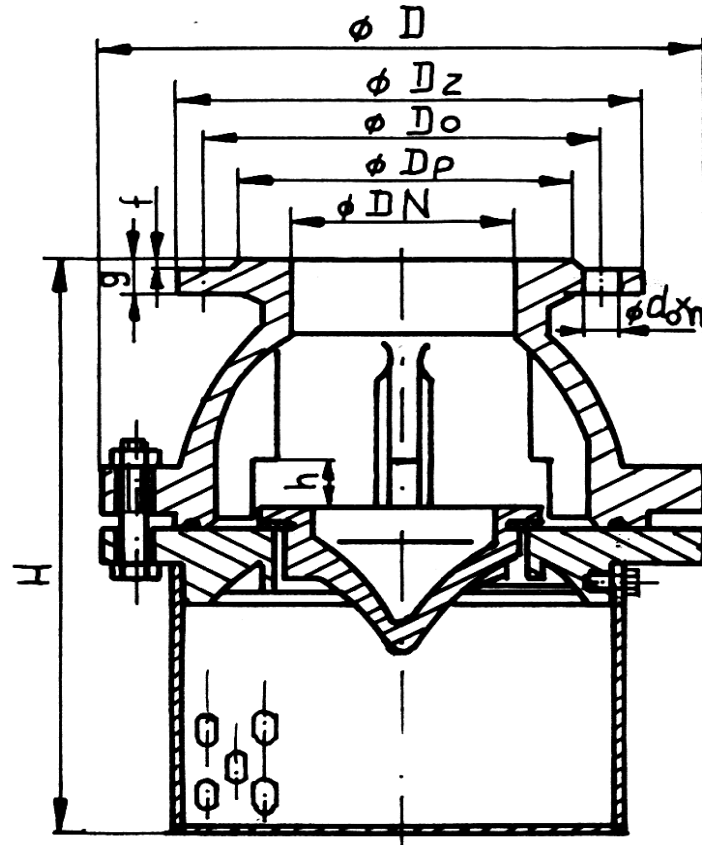

DN	D	H	Dz	Do	Dp	g	f	do	n	h	kg
40	190	180	150	110	88	16	3	18	4	20	7,20
50	205	190	165	125	102	16	3	18	4	20	8,65
65	225	225	185	145	122	16	3	18	4	22	12,45
80	264	250	200	160	138	18	3	18	8	25	16,00
100	280	309	220	180	158	18	3	18	8	27	21,80
125	340	361	250	210	188	20	3	18	8	29,5	32,70
150	362	458	285	240	212	20	3	22	8	39	41,50
200	460	564	340	295	268	22	3	22	8	51	68,30
250	630	575	394	350	320	24	3	22	12	51	131,90
300	630	684	445	400	370	24	4	22	12	71	141,90